

# SKYBOLT

AEROSPACE FASTENERS

## MarineLoc™ Marine Fastener Apps

**Typical Switch Panel.** The actual conditions of this panel are far worse than the picture suggests. In fact, the panel is completely split along a line at the top of the rocker switches.



Besides the obvious cracks around the screw holes, the true liability of a panel in this condition lies with the first technician that attempts to deal with any issues of the radios or a simple blown fuse behind the panel. When this panel was removed for replacement, the panel basically shattered into no

less than 10 pieces initially. Before all wires were identified and removed from each switch, I had approximately 20 pieces of the panel headed for the waste can. No technician in his or her right mind would attempt to remove a panel like this even to search for a blown fuse. Unfortunately, hundreds, if not thousands of pristine boats were manufactured with this brittle material.

Replacement dash panels are available. Skybolt obtained our panels from FP Marine, [www.fpmarine.com](http://www.fpmarine.com), 321-639-2951. The quality was excellent and the material is not brittle in the new condition. We also obtained from FP Marine all new switches and rocker covers.

**Skybolt** is the aerospace manufacturing business of quality ¼-Turn panel fasteners. It was only natural for us to plan our installation around these fasteners versus the standard screw mount. Screws have a distinguished advantage over a quality aerospace quick release fastener; they are cheap. Beyond cheap, is the unplanned expense or consequence of a simple screw mentality.

Screw Advantages –

- 1) They are cheap.
- 2) There are no other advantages.

Screw Disadvantages –

- 1) Screws can and are over tightened so that they tend to remain tight. That process alone stresses most materials and under mild conditions, the material is prone to cracks. Many materials succumb to work hardening from no provisions to flex, thus cracks are formed. Screws are a rigid attachment that allows most materials to crack over time in even mild conditions. Boats and airplanes are not exactly mild condition components. Use a screw because it is cheap and pay for it with cracked panels. Take a vessel worth \$1m new and up; wait about 2 years and pride yourself on cheap panel screws. Details count at little to not incremental cost.
- 2) Screws fall out and are lost when removed. Your technician searches his tool chest and finds a similar screw and replaces it; but maybe not. If 10 screws were in the panel....8 will probably work to.
- 3) Screws strip threads.
- 4) It takes time to remove and re-install screws.
- 5) Screws are not so cheap in the long run.

Skybolt CLoc® Advantages –

- 1) CLoc® fasteners are spring loaded fasteners. Thus, they have the property of a shock absorbing fastener. This stops work hardening of the material and stress cracks due to over tightening.
- 2) CLoc® fasteners are captive. They do not fall out when unlocked.
- 3) It takes no time to unlock and remove a panel.
- 4) CLoc® fasteners pay for themselves after the first repair billing for labor to remove and re-install your panel.

Skybolt CLoc® Disadvantages –

- 1) They cost more than a screw in the short term even though they save far more in expenses in the long term.
- 2) Time required for panel preparation.

Skybolt is devoted to fastener innovations that make an aerospace fastener design more user friendly to marine markets. First, many Skybolt designs are adjustable to provide the perfect fit and locked tension for a vast range of panel thicknesses. Along with adjustment features, we also design more efficient installation techniques that place quick release ¼-Turn Fastener on par with a simple screw.

To install a Skybolt CLoc® fastener, start with the same procedure as installing a screw: Drill holes in the outer and inner panel. Assuming the pilot hole is the correct size for the screw threads, remove the outer panel and drill the hole oversized for the body of the screw. Install the screw. For a screw, this 3-step process basically completes the process.

The Skybolt CLoc® system design for marine applications adds to that 3-step process and makes it a 9-step (simple) process. After a pilot hole is drilled, both the inner panel hole and the outer panel holes need to be properly sized.

**Tools Required** – Battery operated drill. Jig Saw. Electrical Tape. 1/8-inch drill bit. Unibit-1 Stepdrill. 7/16-20 Tap. LockTite 242 Blue Thread Locker. Flat Blade Screwdriver. Portable Workbench. Vacuum Cleaner. Epoxy or resin filler for existing inner panel holes.



This process (shown above) may be the most concern when attempting to replace a switch panel. On this Sea Ray 380 Sundancer, there are over 100 wires just for the

rocker switches. Fearing what might happen when I began removing wires and switches, I ordered all new switches and covers along with the new panels. Lowes/Home Depot/Ace has wire labels in the electrical section. I purchased a book with all numbers and a book with numbers and Alpha characters. Using page 22 from the 2001 Sundancer Parts Manual, I diagramed each switch and assigned a number for each wire along with an Alpha character (1A, 2A, 3A, 4A.....5B, 6B, 7B, 8B.....), then wrapped each switch bundle so as to keep things organized. My process worked as when I reinstalled all switches and wires, everything worked!

Step 1 – (After removal of old panel and marking wires). Lay new panel in position. Drill a 1/8 pilot hole in both outer and inner panels.

**Tip - Recommendation – Warning**

- *Never use a standard drill bit for hole much larger than 3/6. The Unibit-1 is the only tool to consider when drilling most fiberglass or composite holes –*

Step 2 – Remove outer Panel (dash panel). Place a piece of tape just above the 11/32 step on the drill. Drill Outer panel (Unibit-1) to 11/32.

Step 3 – Lay out and cut holes for electronics if installed in panel.

Step 4 – Place a piece of tape just above the 13/32 step on the drill. Drill the inner panel (dash frame) to 13/32.

Step 5 – Tap the inner panel (dash frame) with a 7/16-20 tap. Apply LockTite 242 Blue thread locking compound to SK210-31S Inserts. Install SK210-31S inserts with flat blade screwdriver leaving 1 to 2 threads exposed (we will set the proper depth in the next step).

Step 6 – Position panel (with gaskets if required). Install studs and attempt to lock with a push-turn motion so as to not turn the inserts (excessively). If the correct stud part number is being used (proper stud length for the application thickness), each stud should lock into the insert such that the head of the stud is protruding above the face of the cup. Ideally, when the studs (inserts) are adjusted, the heads are flush with the cup and the insert is flush to the surface of the inner panel. If this is not the case, the studs being used may be too short or too long for the application. Recheck the Stud Length Chart. Note: This step was to insure that the proper studs are being used. In Step 8, we will re-install the panel after stud retainers have been installed, then adjust the inserts to the proper depth.

Step 7 – With a push-turn motion, unlock and remove studs. Remove panel. Place panel on a clean flat surface up-side-down. Slip studs into holes facing upwards and install retainers with T-26 tool. Place retainer carefully onto end of cup and press retainer fully onto the cup to secure each stud.

Step 8 – Install the outer panel and attempt to lock all CLoc® studs. Continue to screw studs (also turning the inserts) until they are drawn to the proper locked condition. This is when the panels are clamped and the stud head is flush with the cup surface. Do not tighten studs such that the face of the stud is below the face of the cup or you will not be able to unlock the fasteners. Check alignment and panel fit is satisfactory. Allow the thread locker to set (5-10 minutes) before unlocking fasteners.

Step 9 – Unlock and lock fasteners and note that the inserts are secure (tight) and do not attempt to unscrew. If the inserts are not secure and you allow them to turn clockwise too far, you will not be able to lock that stud. Check all fasteners lock and unlock as a ¼-Turn Fastener before the inserts are completely secure. Adjust as necessary.

Install electronics/gauges/wires.

You now have a quick release panel with captive fasteners. This extra effort will pay for itself the first time maintenance is required for any switch, fuse, wiring issue, or electronics that require servicing. Your panel will not crack and your \$1m vessel reflects what it is intended to reflect: quality with attention to detail.

We will use pictures of our recent panel installation on a 38 Sea Ray to elaborate each step. Note: Replacing all panels on a Sea Ray 38 required approximately 12 man hours of which 3 hours was removing and carefully marking about 100 wires.



**Step 1** – The replacement panel blank had predrilled holes. That required us to fill all previous holes in the inner dash frame panel. Even if the holes were not pre-drilled, locating the existing inner panel holes to the outer panel may not be simple. Same rule applies with a screw.



**Step 2** – Using tape for a visual stop guide, drill the outer panel to 11/32. Place the tape one step above the 11/32 step (3/8 step)...do not drill to 3/8.

**Step 3** - Note: Layout and cut electronics cutouts. before installing fastener retainers.



**Step 4** – Drill Inner Frame holes to 13/32. This is the third step down from the top or place a piece of tape around the step just above 13/32 (the 7/16 step)...do not drill to 7/16.



**Step 5** – Tap each hole to 7/16-20.



Apply LockTite 242 Blue thread locker to threads of SK210-31S. Install SK210-31S Inserts with flat blade screw driver.

Pre-set inserts with 1 to 2 threads exposed.



Inner Frame Panel with SK210-31S Inserts installed and pre-positioned.

**Step 6** - The replacement panels are .175 inches thick. Referring to chart on page 12, SK27S3, the recommended stud length is -7.

This step insures that we are using the proper length studs for this panel thickness.

Position panel (with gaskets if required). Install studs and attempt to lock with a push-turn motion so as to not turn the inserts (excessively). If the correct stud part number is being used (proper stud length for the application thickness), each stud should lock into the insert such that the head of the stud is protruding above the face of the cup. Ideally, when the studs (inserts) are adjusted, the heads will be flush with the cup and the insert is flush to the surface of the inner panel. If this is not the case, the studs being used may be too short or too long for the application. Recheck the Stud Length Chart. Note: This step was to insure that the proper studs are being used. In Step 8, we will re-install the panel after stud retainers have been installed, then adjust the inserts to the proper depth.

**Step 7** – With a push-turn motion, unlock and remove studs. Remove panel.

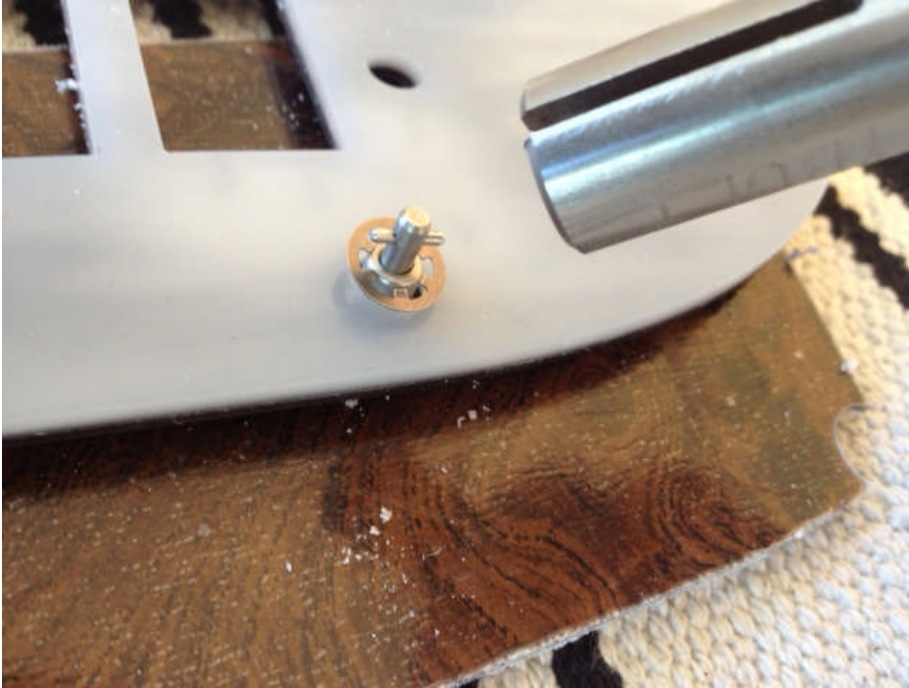

**Step 7– Continued**

Place panel on a clean flat surface up-side-down. Slip studs into holes facing upwards and install retainers with T-26 tool. Place retainer carefully onto end of cup and press retainer fully onto the cup to secure each stud.



**Step 8 –** Install the outer panel and attempt to lock all CLoc® studs. Continue to screw studs (also turning the inserts) until they are drawn to the proper locked condition. This is when the panels are clamped and the stud head is flush with the cup surface. Do not tighten studs such that the face of the stud is below the

face of the cup or you will not be able to unlock the fasteners. Check alignment and panel fit is satisfactory. Allow the thread locker to set (5-10 minutes) before unlocking fasteners. Note: If inserts are too tight to turn via the stud, use tape to mark each stud that needs adjustment with panel removed, use a flat blade screwdriver to adjust insert.

**Step 9** - Unlock and lock fasteners and note that the inserts are secure (tight) and do not attempt to unscrew. If the inserts are not secure and you allow them to turn clockwise too far, you will not be able to lock or unlock that stud. Check all fasteners lock and unlock as a ¼-Turn Fastener before the inserts are completely secure. Adjust as necessary.

Install electronics/gauges/wires.



Completed installation – Screws....about 8 man-hours. CLoc® fasteners....about 12 man-hours (all panels). With the Skybolt CLoc® fastening system, I can remove this panel in about 20 seconds; not chase runaway parts; find a fuse or a bad connection; service; then secure the panel in about 25 seconds. Is it worth the effort? With screws, I may have the opportunity to repeat this process in about 2 years but then, my wires are all marked, thus I can redo the same job in about 2 hours less time.



## Skybolt CLoc® 2000 Series Fastener

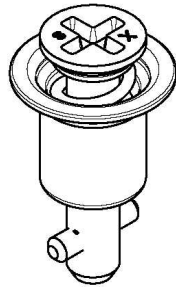

**CLoc® SK27S3 Series Stud**



**CLoc® SK2600-LWS Series Retainer**



**CLoc® SK210-31S Series Receptacle**

## Skybolt CLoc® 2000 Series Threaded Receptacles SK210 Series Rivetless Receptacles - Adjustable Depth

Excellent for any Non-Blind Mounting Application  
Ideal for Marine and Industrial Applications  
Adjustable Depth  
Use thread locking compound to secure insert

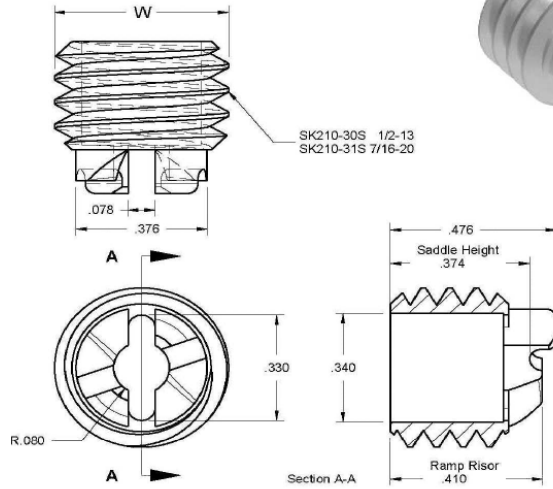

	Material	Thread-Type	W'	Alum, Brass, Plastic		Steel, SS, Iron		Minimum (2) Inner Panel
				Drill Hole To(1)	Drill Hole To(1)	Tap	Drill Hole To(1)	
<b>SK210-30S*</b>	303 Stainless	1/2-13 Tapped	.496	15/32		1/2-13	.250 Min	
<b>SK210-31A</b>	6061 Aluminum	7/16-20 Tapped	.438	11/32	25/64 (2)	7/16-20	.250 Min	
<b>SK210-31S</b>	303 Stainless	7/16-20 Tapped	.438	11/32	25/64 (2)	7/16-20	.250 Min	

Notes: (1) Do not attempt to drill plastics/fiberglass with standard drill bits. Use Unibit-1. Lock threads with Loctite 242 Blue. (2) Full thread length.

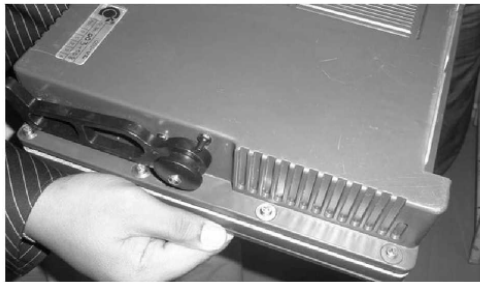

SK28S3 Stainless Studs installed into SK210-31S Receptacles

<b>Stud Grip Chart</b>				
Protruding Stud (1)	Outer Panel		Outer Panel	
	Thickness	Flush Stud (1)	Thickness	
SK26S51-1	.075-.105	SK27S3-1S	.010-.019	
SK26S51-2	.105-.135	SK27S3-2S	.020-.049	
SK26S51-3	.135-.165	SK27S3-3S	.050-.079	
SK26S51-4	.165-.195	SK27S3-4S	.080-.109	
SK26S51-5	.195-.225	SK27S3-5S	.110-.139	
SK26S51-6	.225-.255	SK27S3-6S	.140-.169	
SK26S51-7	.255-.285	SK27S3-7S	.170-.199	
SK26S51-8	.285-.315	SK27S3-8S	.200-.229	
SK26S51-9	.315-.345	SK27S3-9S	.230-.259	
SK26S51-10	.345-.375	SK27S3-10S	.260-.289	
SK26S51-11	.375-.405	SK27S3-11S	.290-.319	

Charts also apply to all SK2600 Series and SK2700/2800 Series Studs.